

1 Start Here



Quickstart Guide - AyrMesh® HubDuo

Check Contents of the box:

1. HubDuo Radio
2. Antennae (2)
3. Power Supply
4. Power Cord
5. (2) Ethernet Cables (1 shorter, 1 longer)
6. (2) Zip Ties (not shown)
7. (2) Screws (not shown)

START HERE:

Remove the door, write down the MAC address of your Hub in the box below, and keep it with these directions in a safe place:

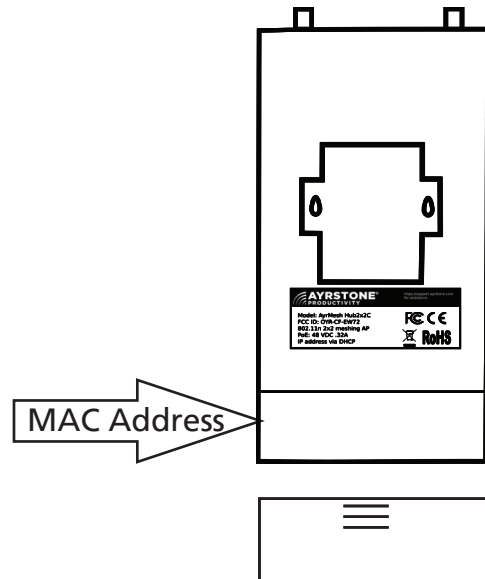
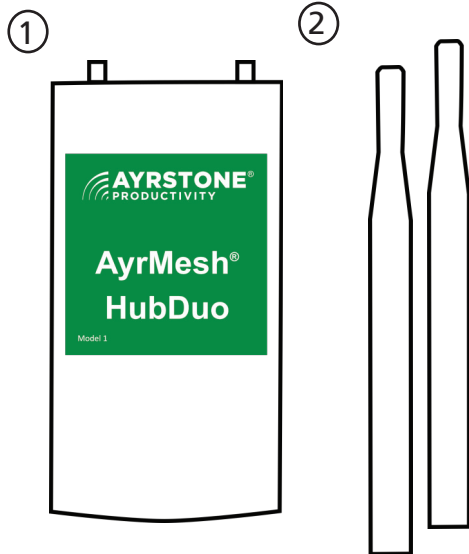

If you don't have an account on AyrMesh.com, create one now using a device connected to your network (not a cellphone unless it's connected to your router via WiFi):

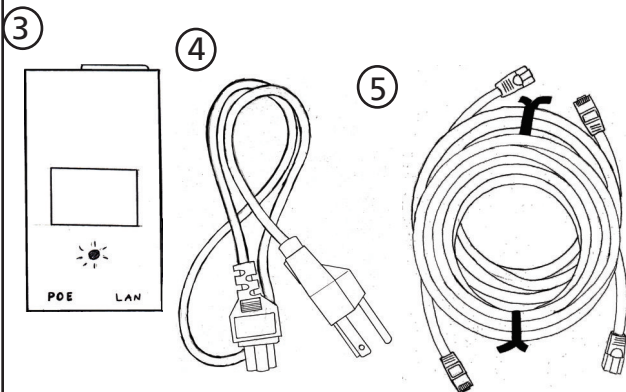

* Username

* Password

Login

[Forgot password ?](#)

[No account? Sign up here](#)

2 Assemble the Hub and Connect to Router to Initialize

A. Screw the antennae gently onto the threads on the Hub - finger-tight (no tools):



B. Plug an Ethernet cable into either port on the Hub - slide in until it clicks in place:

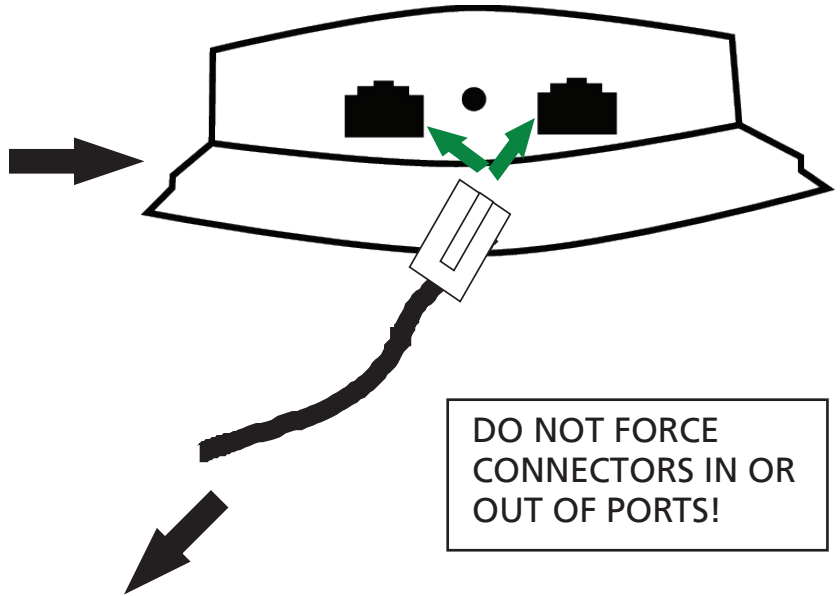

C. Click the other end of the Ethernet cable into the port on the Hub's power supply marked "POE":

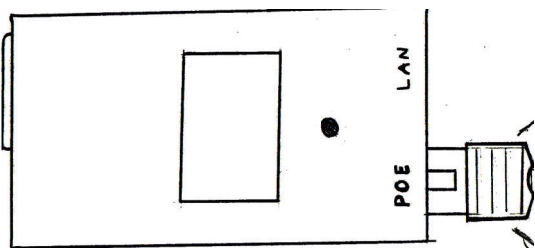

D. Use another Ethernet cable to connect the LAN port of the power supply to one of the LAN ports on your router.

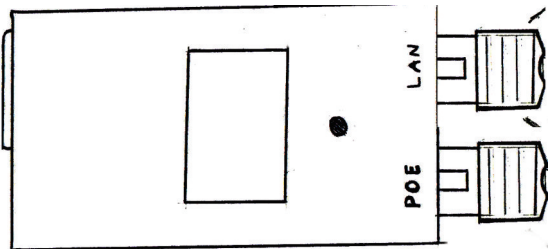

E. Plug the power supply into the wall:

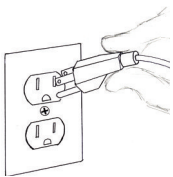

This is how the setup should look:

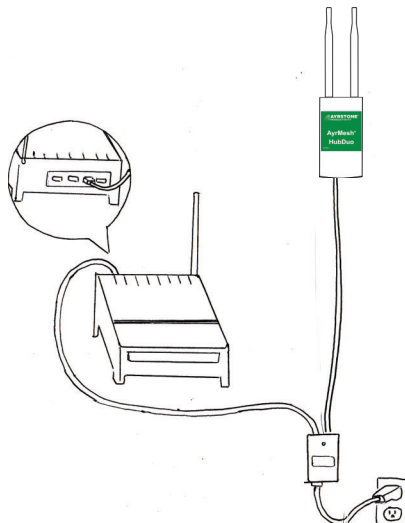

F. The Power light should be on; one of the Ethernet lights and the top light should also start blinking:

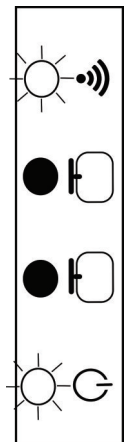

Make sure only ONE AyrMesh device is connected to your router at a time!

3

Make Sure Hub is Working

It usually takes a couple minutes for the Hub to check in and show up on AyrMesh.com, but sometimes it takes a bit longer. Take your time.

The TOP light will flash while the Hub is booting and checking in to AyrMesh.com, and one of the two lights below will continue to blink. When the Hub has checked in to AyrMesh.com, the TOP light will be on steady - not blinking. Make sure you wait for that.

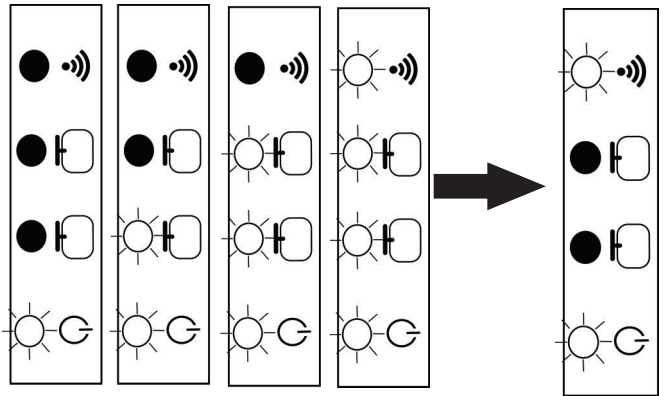
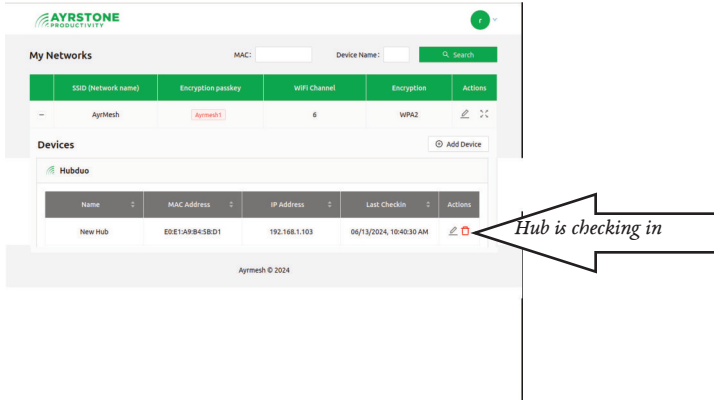

If it hasn't shown up after 5 minutes, try adding it manually: Click on the button that says "Manually add Ayrstone Device" and enter the MAC address

4

Finish the installation

All Hubs should be mounted outside, up as high as possible, with the antennae pointing straight up.

Maximum range for the Hub depends on having clear line-of-sight.

The Hub can be mounted to a flat surface with two screws, or to a pole with the included zip ties.

Click the Ethernet cable from the Power Supply into either Ethernet port on the bottom of the Hub.

Carefully put the door back on the Hub - make sure the cable is in one of the cutouts in the bottom of the Hub.

When mounting the Hub, make sure to leave a "Drip Loop" in the cable where it enters the building so water does not run down the cable to the power supply.

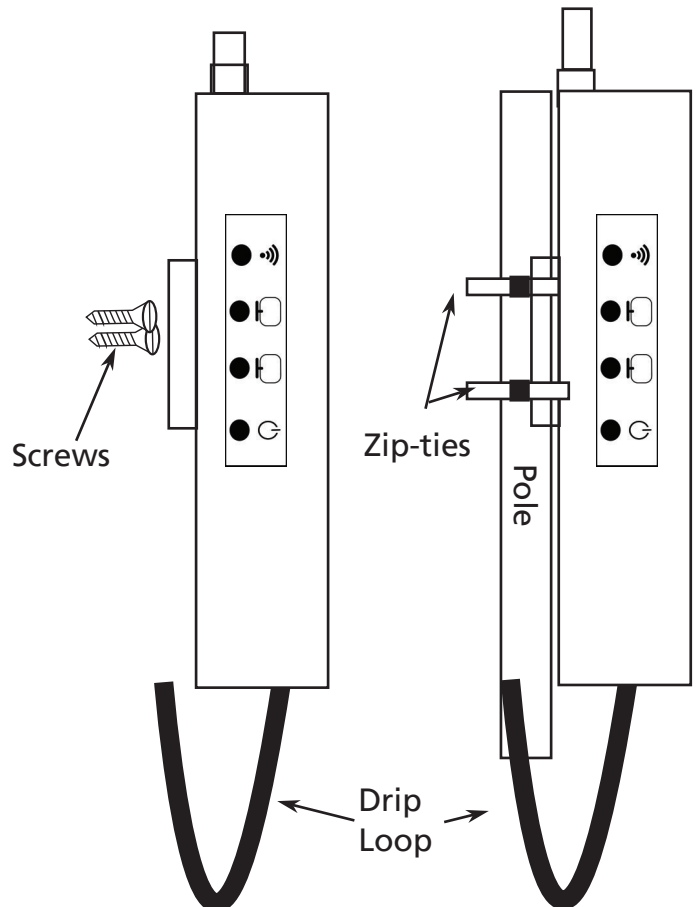

5 Signal lights on the Hub

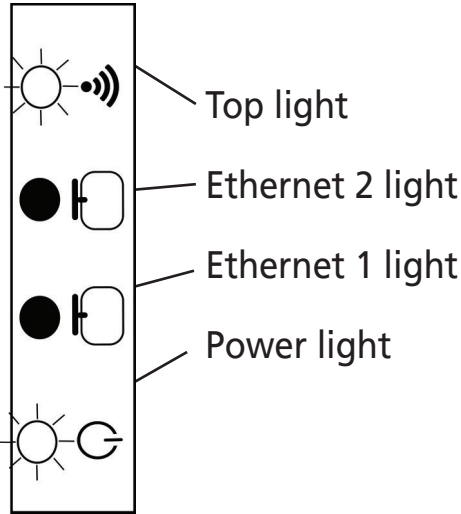

Gateway Hubs have the Power light on steady, and the Top Signal light on steady. One of the Ethernet lights will be blinking.

Remote Hubs have the Power light on steady, one or both of the Ethernet lights blinking, and the top signal light flashing once per second. If the light is blinking rapidly, it is not in contact with the rest of the network.

6 Using the Hub

The AyrMesh HubDuo provides normal 802.11ac WiFi, just like any other WiFi access point. Unless you have changed it in your AyrMesh.com account, the default SSID is "AyrMesh" and the default encryption passkey is "Ayrmeshr" (note the capital "A" and the number "1").

NOTE: Once you have tested the Hubs, **MAKE SURE** you **CHANGE THE ENCRYPTION PASKEY** (and the SSID if you want) in your AyrMesh.com account to ensure the security of your network!

Changes on AyrMesh.com may take up to 15 minutes to take effect on your network - the Hubs wait before changing to make sure all the devices in the network receive the new configuration.

The AyrMesh network extends the IP network of your router, so, from a networking perspective, everything connected to the AyrMesh network appears as if connected directly to your router.

Select AyrMesh network (default: AyrMesh)

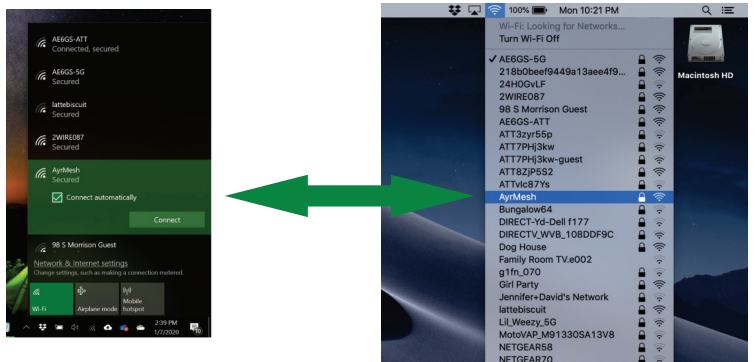

Enter the paskey (default: Ayrmesh1)

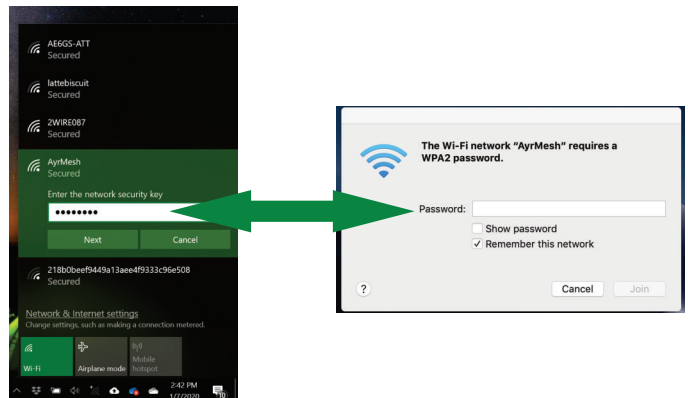

7

Troubleshooting

• NO LIGHTS ON

- make sure power supply light is on steady (not pulsing or blinking); if not, make sure power cable is fully plugged into power supply and into the wall plug. Make sure the wall plug has power. If power supply won't light up, contact Ayrstone support.

- check cables: make sure all cables are fully clicked into place; use a known-good short Ethernet cable (available at most hardware stores).

• SIGNAL LIGHTS CONTINUE TO "CHASE" AND/OR HUB DOES NOT CHECK IN TO AYRMESH.COM

- If Hub does not appear in your account, enter the MAC address into your account on AyrMesh.com by hand.

- Gateway Hub

- check the cables between the Hub and the power supply and the power supply and the router - replace with known-good short Ethernet cables.

- check to see if the Hub appears in the DHCP list (sometimes called "connected devices") on your router. If it does, check your router configuration to see if there is some sort of web blocking enabled or some other problem. Try a "factory reset" on your router.

- Remote Hub

- Make sure the Hub is getting good signal from the nearest "upstream" Hub - make sure it is within 2 miles, that the "Fresnel zone" between the Hubs is mostly clear, and that there isn't too much interference on the channel selected on AyrMesh.com.

• DIFFICULT TO CONNECT TO THE WIFI SIGNAL

- Don't use special characters (especially "%", "#", "&," and "\$") or spaces in the SSID or encryption passkey.

- Make sure you are spelling the passkey correctly - for example, the capital "A" in "Ayrmeshr"

- Solid objects will significantly weaken the strength of the WiFi signal - trees and wood-and-drywall walls will weaken the signal significantly, while bricks or stones may block the signal and anything metallic will almost certainly block the signal completely.

- The signal may be relatively weak directly beneath the Hub - the high-gain antenna is designed to cast the signal out toward the horizon rather than up or down from the Hub.

• NETWORK CRASHES AFTER AYRMESH DEVICE ADDED

- Check for another router - do not use secondary routers on your network unless you understand IP networking, especially subnets and NAT.

- Check for static addresses on your network - do not use static IP addresses on devices in your network; use DHCP reservations instead to avoid IP address conflicts.

- Check for network loops - commonly caused by devices with multiple ways to connect to the network (e.g. laptops, printers, or cameras with both Ethernet and WiFi)

See <http://support.ayrstone.com> for additional information, hints, and troubleshooting tips.

ULTRA-QUICKSTART GUIDE

These minimized directions are intended for more knowledgeable or experienced installers, or just for the impatient. Turn this booklet over for more in-depth instructions, and see <https://support.ayrstone.com> for additional information.

1 GET READY: Write down the MAC address of the Hub in the box below and put it someplace safe. If you haven't already, create an account on AyrMesh.com from a computer connected to the same router that the Hub will be connected to. This ensures you won't have to enter the Hub's MAC address manually.

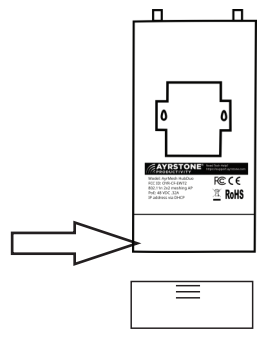

2 ASSEMBLE: Screw the antennae into the top of the Hub (finger-tight, no tools), then open the door on the bottom of the Hub, exposing the Ethernet ports.



3 INITIALIZE: With an Ethernet cable, connect the LAN port of the Power Supply to your router. With another Ethernet cable, connect the PoE port of the Power Supply to the "PoE In" port on the Hub. Plug in the power supply (lights on the Hub will go on). Wait until the Hub checks in to AyrMesh.com - the signal lights will flash slow to fast, then the top signal light will remain lit. This should take a couple of minutes.

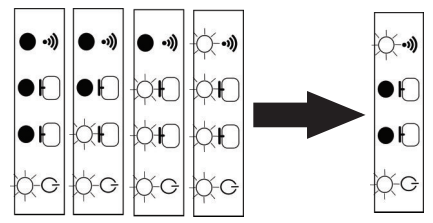
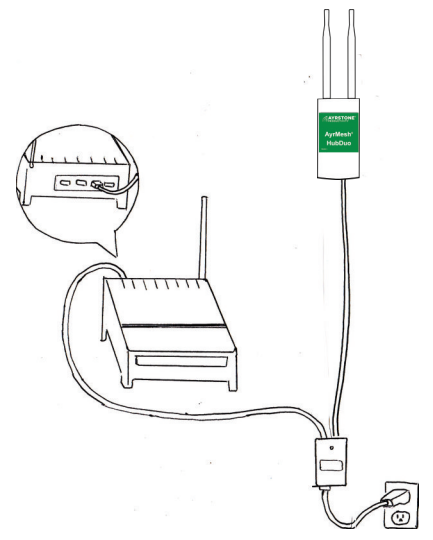

4 INSTALL: Mount the Hub outdoors, as high and "in the clear" as possible. Run a long (preferably shielded - STP) Ethernet cable from the power supply (which must be kept dry) to the Hub - remember to leave a "drip loop" where the cable enters the building to prevent water from coming down the cable inside. The Gateway Hub must have the "LAN" port of the power supply connected to the Router; Remote Hubs have the LAN port available for connecting other devices.

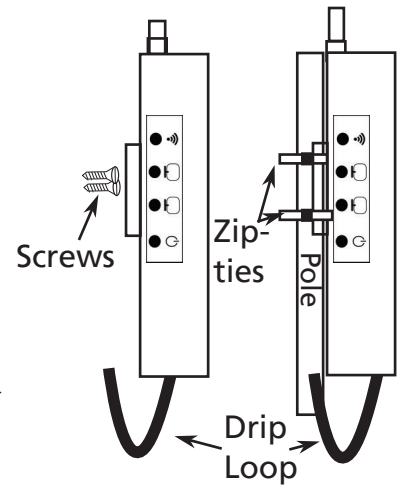

See <http://support.ayrstone.com> for additional information, hints, and troubleshooting tips.